

HIGH QUALITY PIG BUILDINGS

DESIGNED AND BUILT FOR BETTER PERFORMANCE



INVEST IN YOUR FUTURE WITH ARM BUILDINGS

TRANSFORM PRODUCTIVITY; WATCH YOUR COSTS TUMBLE

ARM Buildings have manufactured specialist pig buildings for over 35 years. Owned by the A. Proctor Group since 1999, it is one of the largest suppliers of pig buildings in the U.K.

Our buildings are manufactured using the company's own factory-made laminated panel system. The value of its laminated insulation panels has been recognised outside agriculture and these are now used by the general construction industry.

ARM Buildings are equipped with the best available equipment and materials and include monitored ventilation systems with a free 12 month subscription to 'Barn Report Pro'.

ARM Buildings is a design and build company, designing to suit individual farm requirements, and this flexible attitude has given ARM Buildings an international reputation for providing the best package available today.

As well as supplying new buildings as a complete package, buildings can be delivered in kit form. Refurbishment projects are also undertaken and a wide range of equipment from slats to feed systems are available.

ARM Buildings offer a full project management service including base-works construction, erection of buildings, installation of equipment and a Full Planning service.

Justifying the cost of new buildings;

THE RULES

As feed becomes more expensive its efficient use assumes greater importance. Feed loss and FCR are reduced in new buildings.

Temperature and air quality are easier to regulate in new buildings.

UK average labour hours / pig produced 1.1 hours v DK & NL 0.6hrs due to their greater investment in buildings.

Cost of disease control, the effect of health on performance, and hygiene costs are all reduced in newer Buildings.

Lower running costs – electricity, cleaning, water usage and labour.

Batch production and pig flow are easier to achieve.

Staff morale and retention are improved.

Confidence is required – but the payback can be significant.

Pig buildings are classed as either Building or Plant for tax purposes.

Plant can be 75% or more of the total building cost and includes: Slurry storage, slats, pen / room divisions, feed system, electrics, plumbing, ventilation, wall coverings and insulation.

Plant and equipment (75% of investment costs) qualify for capital allowances.

Building structures (25% of investment costs) are generally written off over 20 years, although most modern buildings will last considerably longer.





EXAMPLE

1000 Place Fully Slatted Ventilated Finishing House - Centre Passage, 2 Rooms

To supply, construct & erect building and equipment,
on a four block deep baseworks

Budget Price: **£215.00 +VAT /pig** (price valid as at June 2017)

SPECIFICATION:

Size: Nominally 16.28m x 48.42m.

Laminated Panel Height Eaves, nominally 2.42m with Stainless Steel Flashing to Slat level.

Roof pitch 1:4, nominally 14 degrees.

Rooms: Building to be in 2No rooms,
each nominally 16.00m x 24.00m Internally.

Pens: A total of 20No Pens, each pen is to accommodate
50No pigs and measures 4.80m x 7.50m
providing nominally 0.72m² per pig.

CONSTRUCTION AND EQUIPMENT

Wall Panels:

72mm stud frames, 72mm thickness expanded polystyrene boards between studs. Internal faces of panels are clad with 3mm thickness Polypropylene.

External face of panels are clad with 6mm thickness Flexstone textured GRP.

Cladding materials are laminated to the timber and polystyrene using a heat and moisture resistant glue.

Panels secured to Baseworks with a stainless steel flashing down to slat level.

Ceilings:

72mm SDVB expanded polystyrene board with white faced Formica vacuum bonded to both faces using a heat and moisture resistant glue.

Roof:

Profile 6 fibre cement roof sheets in a natural finish with flashings to match, supported on SC3 timber Purlins, CCA treated.

Gutters:

Each side to have Marley 110mm deepflow rainwater system in grey PVC.

Portals:

Timber Portals to ARM design with 4No galvanised steel props per portal.

Penning:

Paneltim plastic panel penning and Hurdle type gates with galvanised steel posts and stainless steel fixings, colour – Green. All penning would be 1.00m high.

Plumbing:

2No Plastic storage tanks to be installed.

Down pipes to drinkers to be stainless steel.

5No Bite drinker per pen to be mounted on the pen division.

Electrics:

1No 1ph-consumer unit fitted with an RCD incomer and a surge protection unit. MCB's to all circuits.

Lighting to be a total of 20No 1.5m vapour-proof fluorescent fittings, operated by 2-way switches.

Power will be provided by 2No 13A switched sockets and 2No 240V 16A interlocked sockets.

Flooring:

All rooms to be totally slatted using square edged Dry cast concrete slats.

Controlled Inlet Ventilation:

Ventilation is provided by 4No 630mm diameter fans, roof mounted in high speed exhaust chimneys per room.

Fresh air comes into the building through wall mounted, automatically controlled, plastic air inlets. The inlets and fans are adjusted to achieve the desired set temperature and to maintain a constant and even airflow into the building without causing a draught at stock level. The system provides adjustable minimum ventilation either using speed control or interval timing. Fan duty is rotated to extend operating life. The

system is designed to control inside temperature to within +/- 1oC between -5oC and +12oC ambient.

Double glazed windows are included to provide natural light.

Alarm Regulation Compliance:

All livestock housing systems supplied come complete with basic mains failure and temperature alarm fitted as standard. This complies with current regulation in the UK but only offers audible announcement of alarm condition. Various options are available to extend the communication of alarm condition.

System Performance Monitoring:

All new buildings are fitted with system performance monitoring as standard. This comprises network connection of all controllers in the building to a data logger, a cellular modem for remote access to logged data and 12 months subscription to Barn Report Pro software and technical support. The system allows the operator to view logged data for temperatures, ventilation system status and operator settings. Monitoring supports our commitment to providing the best possible growing conditions for housed stock and provides a sound basis to troubleshoot any problems and ensure return on investment. End users may extend data subscription beyond the initial 12 month period if they wish.

Monitoring ensures support systems around the growing pig operate as designed which has been estimated to be worth up to a 30% improvement in productivity.

Control:

2No FSC1.2FFID/AFN/ASN/NET/AST DICAM controllers to be installed.

BASEWORKS

Slurry Pit Base:

150mm-thickness fibre reinforced concrete slab to be cast.

The top of the slab to finish at 900mm below datum, i.e. 4No courses of blockwork.

Slurry Pit Walls:

Gable walls of pit to be constructed using 7N hollow concrete blocks.

Sidewalls constructed using 7N hollow concrete blocks.

Pit dividing walls constructed using 7N hollow concrete blocks.

All blockwork to be filled as it's laid. 4No outside walls of the slurry pit to have a waterproof render applied.

Support Lintels:

Concrete slats are supported on the pit dividing walls and also concrete lintels.

Lintels to be used are "Strongcast" pre-cast concrete.

The lintels are supported on 7N blockwork pillars.

Slurry Sluicing:

200mm-diameter pipe will run under the concrete slab and outlet

points through the slab will connect each section of the pit.

The pipe will terminate at one gable end of the building.

Walls:

1No course of 7N hollow concrete blocks around the top of the slurry pit on which the building will stand.

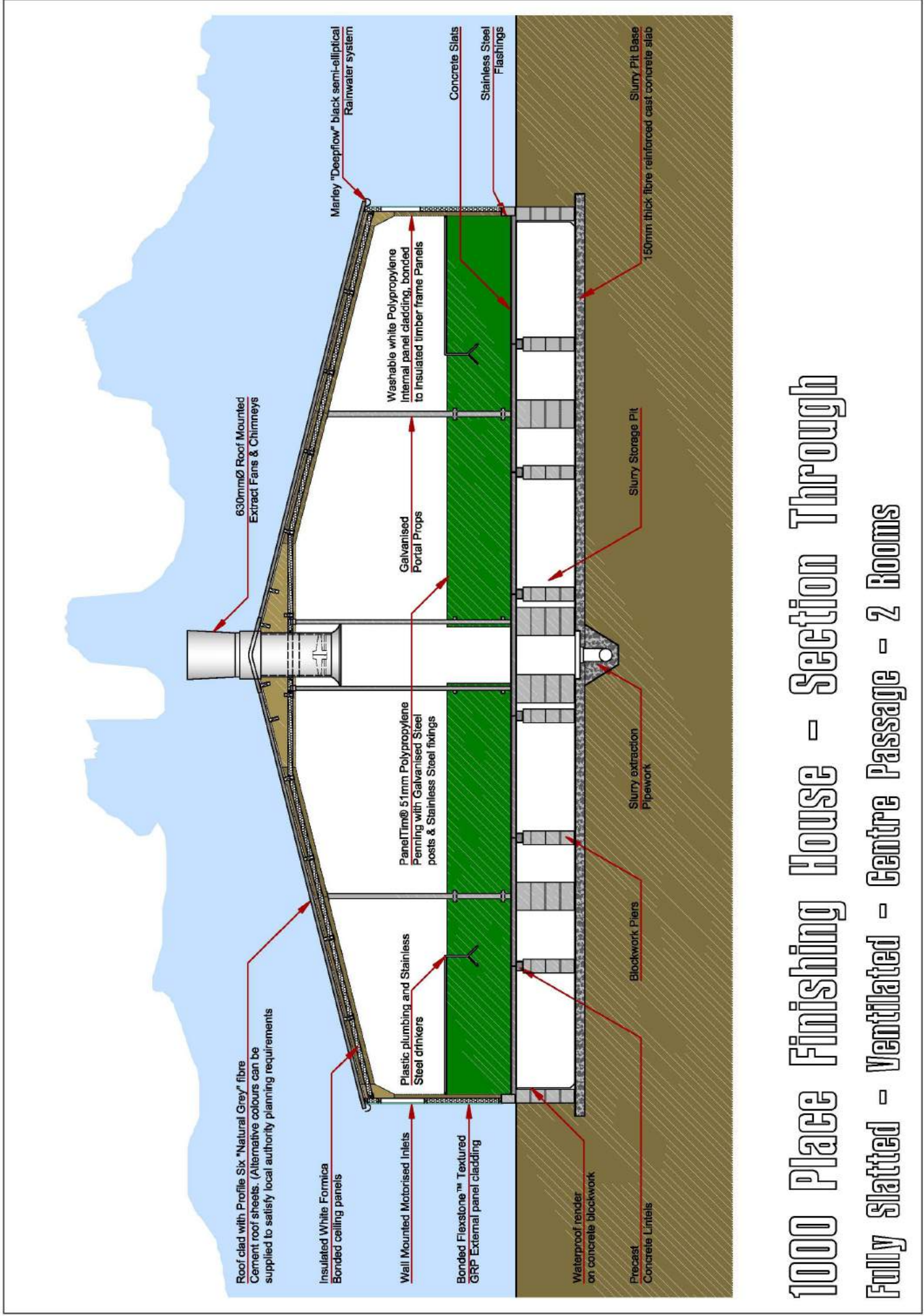

1000 Place Finishing House - Section Through

Fully Slatted - Ventilated - Centre Passage - 2 Rooms

PanelTim®
51mm Pen Gates

Galvanised
Portal Props

PanelTim®
51mm Pen Divisions

Stainless Steel flashing fitted around
perimeter to allow easy cleaning

48.42m

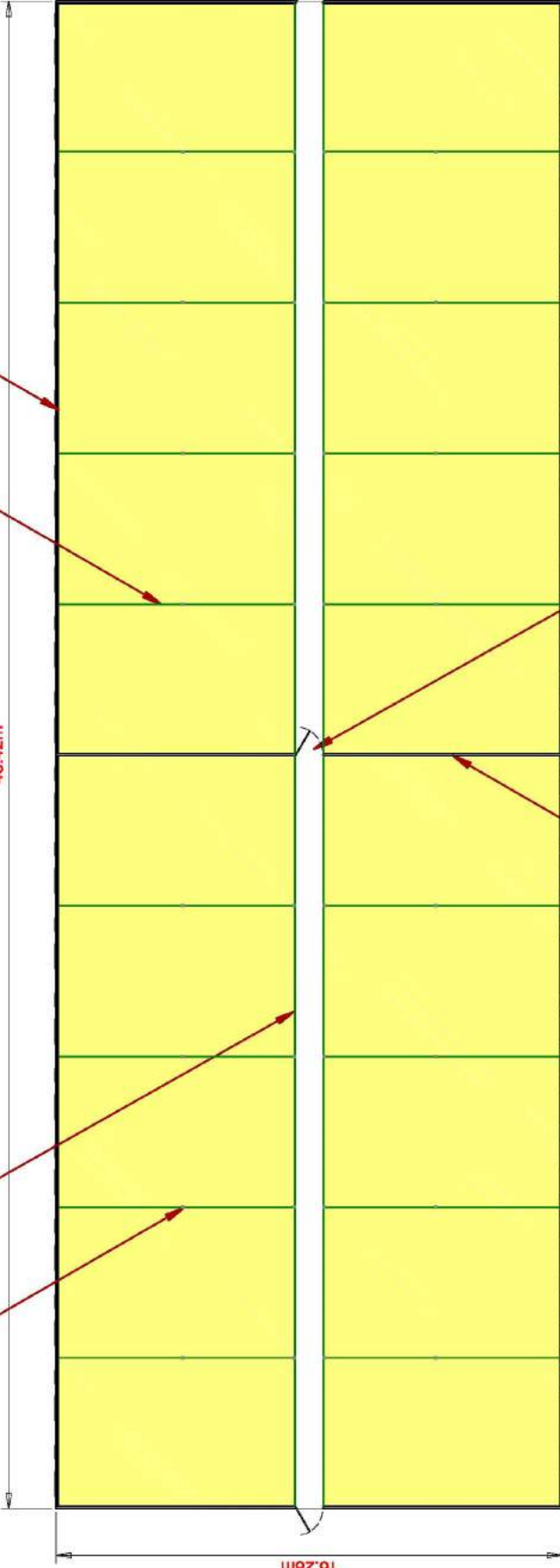

Bonded access door
clad externally with GFRP &
internally with Polypropylene

Partition panels clad with polypropylene both sides,
Bonded to polystyrene insulated timber frame

Access door
to adjoining room

Stainless steel flashing
Fitted to portal leg

1000 Place Finishing House - Plan View

Fully Slatted - Ventilated - Centre Passage - 2 Rooms

FULLY SLATTED FAN VENTILATED FINISHING HOUSE

FINISHERS 35—105 KG GROWING AT 950—1030 G/DAY

A new building results in better performance which results in a quicker payback.

New finishing house £200/pig place 500 pigs/batch

Cost savings:

Better performance FCR -0.5 (£10) and B&B (£8) = £18/pig

Throughput 4.2 batches/year = £76/pig place/year

2.6 year payback excluding any interest payments

Actual figures from a standard finishing house

	Batch 1	Batch 2	Batch 3	Batch 4
Weight in (KG)	39	37	31	31
Weight out (KG)	105	104	103	102
Grow rate g/day	955	985	970	1030
FCR	2.27	2.28	2.27	2.15

POWER COSTS PER PIG PLACE

TOTAL POWER COSTS PER FINISHED PIG £ 1.52

COST PER FINISHED PIG	HEATING	VENTILATION	LIGHTS
FARROWING	£ 0.41	£ 0.08	£ 0.01
WEANER/GROWER	£ 0.28	£ 0.03	£ 0.01
FINISHER	£ 0.00	£ 0.69	£ 0.01
TOTAL	£ 0.69	£ 0.80	£ 0.03

Power estimated at £ 0.10 Kw/hr

YEARLY PERFORMANCE CHECK

We at ARM Buildings offer a 'MOT' service for buildings to help pig farmers run their controlled-environment houses more efficiently. An annual routine check will let farmers know that their piggeries—particularly finishing houses—are performing to optimum levels.

This service will include: Calibration settings for fans and inlets, building performance, Dicam training, building settings and pressure test and air speed measurement.

Inlet calibration can be undertaken along with checking of Dicam drivers; if electrical work or fan replacement is required then advice can be given.

A fee of £300 will cover the visit and advice. If you would like to be included in this planned annual performance calibration please contact Tim Miller on 07 976 701 144



ALL THE BENEFITS OF ARM'S PROVEN HIGH QUALITY INSULATED PANEL SYSTEM WITH THE VERSATILITY A STEEL PORTAL FRAME OFFERS.

STEEL PORTAL FRAME FINISHING HOUSES

Easy to manage with a minimum of labour.

Designed to provide an additional income stream for arable farmers as a stand alone Finishing site, or to complement existing pig enterprises.

Fully slatted with 6 months slurry storage built in.

Concrete panel walling to slat level. Invest in your future with ARM Buildings; transform productivity; watch your costs tumble.

Hygienic surfaces, high insulation values, robust laminated panel design., and EFFICIENT modern ventilation, all contribute to significantly improved performance, lower labour costs, and lower maintenance costs.

COMPETITIVE PRICING MEANS LOW CAPITAL COSTS.

Tax Efficient 85% classed as plant equipment.

Clear span frame design for any future change of use.

40 Year guarantee on external FLEXSTONE cladding.

Health Check contract for the ventilation equipment available.

Kit form or complete package, including base-works and erection, all with our own direct labour force.



WE UNDERTAKE FULL PROJECT MANAGEMENT INCLUDING A COMPREHENSIVE PLANNING SERVICE, BASEWORKS AND ERECTION AND INSTALLATION OF BUILDING AND EQUIPMENT. KIT FORM OPTIONS AVAILABLE.

FANVENT GROWER & FINISHER HOUSES

Designed for maximum productivity with minimum labour, probably the most efficient finishing system available. Common design is adjusted to suit Grower or Finisher pigs. Excellent visibility of pigs at inspection, with easy access to each pen. Option for fully integrated automatic feeding systems include ad-lib dry feeding, ad-lib wet feeding or restrict wet feeding in a full length trough.

Bespoke ventilation system specified to suit each particular application. Powered inlets are linked to the speed of the fans to maintain constant air speeds and temperature. Automatic ventilation 24/7, regardless of location on the pig unit, or the siting of the building in relation to prevailing weather. Greater fan capacity than alternatives on the market, critical in achieving optimum pig performance, with minimum temperature lift in all seasons and over a range of climatic conditions.

A HIGHLY EFFICIENT, FULLY CONTROLLED ENVIRONMENT HOUSE

Farmex Dicam controllers offer unit monitoring with Barn Report Pro.

Hygienic surfaces, high insulation values, robust laminated panel design.

Standard is fully slatted floor with concrete or plastic slat panels. A Straw bedded option can be offered.

Hi-tech laminated insulated panels manufactured in our factory ensure an easy to clean, efficient environment for finishing pigs. A wide range of external cladding materials are available.

40 Year guarantee on external FLEXSTONE cladding.

Low maintenance with polypropylene cladding and stainless steel flashings and brackets.



A MODERN,
EASY TO MANAGE
HOUSE PROVIDING
OPTIMUM
CONDITIONS FOR
SOWS AND LITTER

FARROWING HOUSE

Each Farrowing building is designed to suit the individual herds production requirements, with rooms matching batch sizes.

Cost effective compared with containerised buildings.

Can be written down as 85% plant and equipment.

Low running costs with integrated heat mats built into fully slatted floors.

500mm high plastic pen walls with stainless steel fittings provide robust and easy to clean surfaces.

Galvanised steel farrowing crates with stainless steel troughs.

Hi-tech, factory produced laminated insulated panels provide an efficient and effective environment for rearing piglets.

40 Years warranty on Flexstone exterior wall cladding.

Kit form options available.

Complimentary planning service if required.

ARM Buildings offers full project management, including a comprehensive planning service, base-works, erection and installation.





**DESIGNED TO SUIT
'ALL IN ALL OUT' FOR
WEEKLY OR BATCH
FARROWING
SYSTEMS**

WEANER/GROWER HOUSE

Single stage accommodation will house weaners from 7Kg to 40Kg + means less pig movement and less cleaning out. Highly insulated building design coupled with integrated heating combined to minimise costs.

Options for feeding include ad-lib dry or ad-lib wet feeding. Excellent visibility of pigs at inspection, with easy access to each pen from the central passage.

Ventilation system is specified to suit each application. Our ventilation system has a greater fan capacity than alternatives on the market, critical in achieving optimum pig performance.

Powered inlets are linked to high speed tube fans to maintain constant air speeds and temperature.

Farmex Dicam controllers offer unit monitoring with Barn Report Pro.

Fully slatted floors with plastic slat panels on fibreglass bearing beams. Hi-tech factory produced laminated & insulated wall and ceiling panels provide an easy to clean, modern and efficient environment for weaner/grower pigs.





NATURALLY VENTILATED SYSTEM WITH FRESH AIR AND NATURAL DAYLIGHT. KIT FORM OPTIONS AVAILABLE.

TROBRIDGE® FULLY SLATTED FINISHER

Naturally ventilated system with a UNIQUE advantage, that every pen of pigs is separate from the next, each pen of pigs has its own supply of fresh air and natural daylight.

2 standard pen depths 5m and 6m, 2 standard pen widths 2.5m and 3m to accommodate different group sizes.

Rows of Trobridge units are arranged to suit site and batch sizes.

Flexibility, as units can hold larger no's of smaller pigs or smaller numbers of larger pigs.

Floors may be fully slatted with concrete or plastic panels, eco-slats are available (with solid floor sections).

Standard ACNV package for automatic ventilation of front and rear vent flaps, adjusting flaps 24 hours a day to keep pigs in their optimum comfort zone.

TROBRIDGE® STRAW-BEDDED FINISHER

Trobridge straw bedded units provide a highly efficient, naturally ventilated system where straw bedding is required.

Each pen of pigs has its own fresh air and natural daylight.

Units can be supplied to go under an existing portal frame or ARM Buildings can provide a simple umbrella to cover the passage.





A HIGHLY PRODUCTIVE, NATURALLY VENTILATED FINISHING HOUSE

ACNV GROWER & FINISHER HOUSES

Arranged as 2 rows of pens either side of a central access passage.

Building may be subdivided into rooms depending on batch size.

Common design is adjusted to suit grower or Finisher pigs.

Large, translucent ventilation window flaps are automatically controlled.

Plenty of natural light and generous quantities of fresh air.

Excellent visibility of pigs for daily inspection with easy access to each pen.

Ventilation system continuously monitors the building, adjusting flaps 24 hours a day to keep pigs in their optimum comfort zone.

A HIGHLY PRODUCTIVE, NATURALLY VENTILATED FINISHING HOUSE

Option for automatic feeding systems include ad-lib dry feeding, ad-lib wet feeding or restrict wet feeding in a full length trough.

Flooring may be either straw bedded or fully slatted with concrete or plastic slats. Hi-tech factory produced laminated & insulated wall and ceiling panels provide an easy to clean, modern and efficient environment in which to keep pigs. A wide range of external cladding materials are available.



HIGH QUALITY PIG EQUIPMENT DESIGNED AND BUILT FOR TOP PERFORMANCE



PANELTIM[®] POLYPROPYLENE PANELS

PANELTIM[®] POLYPROPYLENE PANELS

The most popular penning and gate system in use today.

Panels made to measure from hard wearing polypropylene with fully sealed welded edges. Panels 51mm thick.

Full range of Stainless Steel bracketing and gate furniture.

Robust and fully pressure washable and available in a range of colours.

Resistant to all chemical products commonly used in Piggeries.

Suitable for all pigs from weaners to dry sows.

Standard heights: 800mm, 1000mm and 1200mm. Lengths up to 5m long. Other sizes available on request.

SUDING CONCRETE SLATS

HIGH QUALITY CONCRETE SLATS AVAILABLE IN 100MM INCREMENTS,
FROM 600MM TO 3.50M
VERY COMPETITIVELY PRICED (P.O.A.)



AS-18/40 fattening slats

This slatted floor is suitable for rearing and fattening pigs. Because of its maximum void area of 15% at the most this floor can be used in every area of the piggery. Maximum load of 125 kg animal weight. Manufactured according to DIN EN 12737. Concrete strength class: C40/50.



AS-18/50 fattening slats

This slatted floor has the qualities of the AS-18/40. Furthermore this floor has the advantage (because of only 3 differences in depth) of a better combination of short and long concrete elements. Maximum load of 250 kg animal weight. Manufactured according to DIN 18908. Concrete strength class: C40/50.



AS-11/40 weaner slats

With its gap width of 1.1 cm this slatted floor has been developed for suckling piglets. It can also be combined with plastic - or our dihedral floors. Maximum load of 125 kg animal weight. Manufactured according to DIN EN 12737. Concrete strength class: C40/50.



AS-14/40 grower slats

The breeding floors with their gap width of 1.4 cm are specially adjusted to the needs of growers. The tread width of 6.6 cm ensures the required concrete covering and complies with the directive for pig keeping. Maximum load of 125 kg animal weight. Manufactured according to DIN EN 12737. Concrete strength class: C40/50.



AS-20/33 sow slats

This slatted floor with 2.0 cm gap width is used for young sows, sows and boars. Maximum load of 250kg animal weight. Manufactured according to DIN 18908. Concrete strength class: C40/50.



AS-20/40 sow slats

This slatted floor with 2.0 cm gap width is used for young sows, sows and boars. Maximum load of 250 kg animal weight. Manufactured according to DIN 18908. Concrete strength class: C40/50.



ROTECNA PIG EQUIPMENT

TR2 / TR4 / TR5 FEEDER

Polypropylene injection feeder for weaners built in one piece, extremely robust and ergonomic with easy access round shaped bowl with anti-waste trim. Sensible and handy regulation with sandwich internal slide, allowing easy regulation even when full. TR5 with 5 feeding spaces for piglets from 6 to 30Kg. TR4 with hopper extension for piglets from 6 to 40Kg.



SWING DRINKER

A unique swing drinker for weaning and fattening, constant water level drinker, easy access even for small piglets. Up to 50% reduction in water wastage and manure production. Designed for 2-3 piglets at the same time, saving in medication. Swing action helps to maintain water-quality and hygiene

VALVE VR-H

Keeps a constant level of water in bowls therefore increasing water intake. By mixing water and feed, the feed intake is stimulated. Maximises water availability, reducing water spoilage up to 50%



EASY PAN / MINI HOPPER PAN

The use of support feeders for weaners (increasing the number of feeding spaces for 2 weeks) improves feed efficiency and promote regularised growth. Robust, hygienic and animal friendly construction. MAXI HOPPER PAN, 21l. Optional extension and lid available. MAXI PAN, 10 feeding spaces, anti-waste concave bowl. 20 piglets/feeder, for animals from 6 to 18Kg.

FEEDING BALL

Slow drop dispenser is suitable for Maternity and Gestation. Increases the feed intake of the sow. Very easy learning. Helps to avoid feed wastage. Possibility of two types of feeding: restricted and Ad Libitum. Provides for fresh feed 24 hours a day. Makes it easy to see how much feed has been consumed. With the VRH-3 water level valve in the feeder, water consumption is increased considerably. Prevents sow stress. 2 Supports Option: Plastic and stainless steel.



ROTECNA PIG EQUIPMENT



SWING R3

Higher efficiency both for weaning, fattening and wean to finish.

This gives it a wider functionality to respond better to the whole life cycle of the pig from 6Kg with one single product.

- Better learning
- Ideal for meal or pellets
- Easier regulation
- Easier to fill
- Simpler to clean

ROTECNA SLATS

Top quality Plastic, Cast Iron and integrated Heated Slats.

Corrosion resistant support system.

Large stocks available for rapid despatch.

All slats come with a 5-year guarantee



Plastic Sow Slat



Plastic Weaner Slat



Wean to Finish Slat



Blind Plastic Slat



Electric Heated Plate

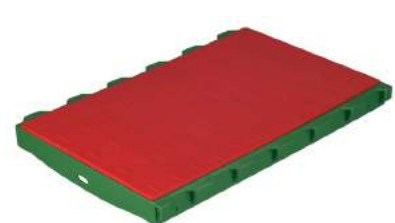

Water Headed Plate



Cast Iron Slats



Ferrocast Iron Slats



Trap - Slat

FLEXSTONE

IDEAL FOR OVERCLADDING EXISTING BUILDINGS

40 YEARS GUARANTEE



ACID PROTECTION MATS

DESIGNED TO REDUCE FEED WASTE
AND STOP WEAR AROUND FEEDERS
ON CONCRETE SLATTED FLOORS



ARM BUILDINGS LTD
ARE THE UK
DISTRIBUTOR OF
OSBORNE BIG
WHEEL FEEDERS
AND STANFIELD
HEAT PADS.

BIG WHEEL FEEDERS

We have the sole UK distributorship for the popular Osborne Big Wheel range of pig feeders.

The American-made feeders are of rugged construction and well proven on farms. A particular feature, as the name suggests, is a multi-spoke wheel attached to the trough, which dispenses feed only when operated by the pigs, helping to eliminate waste and keep the troughs clean.

Feed flow-rate is controlled by an easy-to-use adjustment mechanism which raises or lowers an internal cone. A major advantage with the circular trough system is that there are no corners where feed can build up and become stale, say the manufacturers.

Hoppers are made from reinforced glass-fibre while the metal parts are of galvanised or stainless steel. The feeders are available in a variety of sizes for weaners

through to finishers with capacities ranging from 35 to 529 litres, which will feed up to 60 pigs. The feeders can be free-standing or fitted within pen partitions.

Competitively priced, they are available direct to farmers or through the trade.

In addition, ARM is distributing the Stanfield range of easy-to-clean heat pads for piglets in both farrowing and weaner accommodation, also from Osborne Industries. Available in a range of shapes and sizes to fit different sized pens, they provide a uniform surface temperature 16^o-20^oC above air temperature.



FARROWING FRAME

DESIGNED AND BUILT FOR TOP PERFORMANCE

ARM's standard Farrowing frame has been developed over 15 years and provides a simple, robust and practical design to suit any Farrowing House.

- Fully galvanized frame with a stainless steel trough as standard.
- Suitable for dry or wet feeding.
- Fixing system compatible with fully slatted or solid floor system.
- Side opening for easy sow access, can be fixed on 3 legs only to allow width adjustment.
- Hinged back-gate can be opened either hand.
- Internal length can be varied with reversible gate.
- Very competitively priced and available from stock.

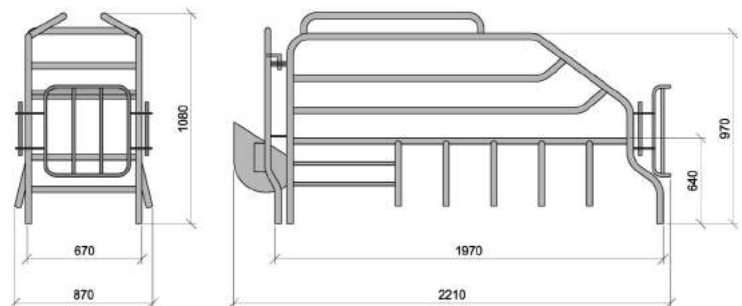

REAL-TIME MONITORING FOR PIG PRODUCTION BARN REPORT PRO™



Barn Report Pro (BRp) is a decision support tool incorporating remote data capture, access, viewing and analysis for pig production professionals.

A network of control or monitor only devices on the production site is permanently connected to the internet using the mobile network or available broadband access on farm. The continuous flow of data from the pig unit is automatically processed on-line and clients get access through secure log on using a browser. BRp operates on Microsoft Windows platforms and access can be provided to any number of people authorised by the client company.

BRp typically collects temperature, feed flow, water disappearance, electricity use, ventilation system component status, light level, humidity, static air pressure, site wind speed and direction and rainfall and any other related data of interest to the client. The unprocessed data can be easily exported for other analysis if required.

BRp has a number of components and is supplied on a quarterly subscription basis depending on the components selected. The core components are SiteMap, Critical Alarm, ActiveCharts and BetterScore. In addition to these data from other systems can be

integrated into BRp such as liquid feed, measured dry feed, feed bin inventory, pig growth and health monitoring. Additional charges are made for these components.

BRp's entry level is charged at £150/ qtr and includes on-line access to the ActiveCharts component and Weekly Summary Reports which become Batch Reports where appropriate at batch end. This means that it is possible to get regular value from the system without the need to log on.

The SiteMap component provides a live view of the pig unit and all devices being monitored. This feature is very useful for a quick check on the farm from anywhere with internet access. The CriticalAlarm component provides flexible and comprehensive alarm cover for your farm that is readily set up to accommodate your staff and deliver alarm announcements using SMS text, voicemail or email. The ActiveCharts component replaces the long established desk-top Barn Report program. More functions, easy to use and still providing access to the detail of what is taking place on farm. The BetterScore component is a notification system based on automatic analysis of data. Specific messages about water leakage, erratic temperature control or feed intake trend can be delivered to the relevant member of staff. If the problem continues unresolved the message can be sent to the next level of management. With suitable training and engagement staff will be able to pay more attention to detail and be more consistent. Your pigs will respond to this improvement.

Full details for the system are available on request. ARM Buildings will be supporting the supply of BRp Entry Level on all new building contracts – please ask for details.

ARM Buildings are the only specialist building supplier to the UK pig industry offering real-time monitoring as standard in their buildings.



Dr Sadie Douglas works with Hugh Crabtree providing Barn Report Pro users with Data Services such as comparative energy use analyses or drinker trials monitoring.



IT SYSTEMS FOR PIG PRODUCTION MANAGEMENT FROM FARMEX – TURNING DATA INTO INFORMATION INTO KNOWLEDGE INTO PROFIT!

ENVITEC BIOGAS AND ARM BUILDINGS UNDER ONE ROOF

SINCE JUNE 2007, ENVITEC BIOGAS HAS HAD A PRESENCE IN THE UK THROUGH ITS JOINT VENTURE WITH ARM BUILDINGS LTD

ENVITEC IS A LEADING SUPPLIER AND OPERATOR OF BIOGAS PLANTS IN EUROPE WITH OVER 600 PLANTS ALREADY IN OPERATION FROM 150KW TO 20MW.

Envitec offers a complete service for plants running on either waste streams or energy crops from planning through construction and start-up to operation and service.

In 2007, due to a surge of interest in on-farm biogas production in the UK, ARM Buildings Ltd and EnviTec Biogas formed a joint venture to offer farmers, who are increasingly turning to biogas, a means of broadening their business interests.

As well as building new biogas plants, EnviTec Biogas UK is expanding its dedicated service team in line with the continued growth of the business.

The company is doubling the headcount of its technical services department as part of a major investment in its operations, to ensure the most comprehensive support for its clients. An extensive training programme has been developed for the new recruits.

EnviTec Biogas UK has also significantly increased its stock of spares, to keep biogas plants running smoothly and downtime to an absolute minimum. The investment comes after the company reported significant financial growth recently. Its strong financial performance, aided by the attractive market conditions in the UK for anaerobic digestion plants, has helped support investment in new initiatives, including farmscale biomethane 'gas to grid' plants. Biogas can offer a cost-effective renewable energy source, whichever configuration is chosen.

Mike McLaughlin, managing director of EnviTec Biogas UK, which has its headquarters in Rugeley, Staffordshire, said: "We are committed to the long-term, planning, building and servicing of AD plants in the UK, and this investment in our service operation reflects that. "Renewable energy from AD represents a robust commercial decision and we are in a prime position to support its continued growth in the UK. AD is a very efficient system, and we have produced a very efficient plant, which is complemented by an extensive service and support package to ensure a smooth-running process."

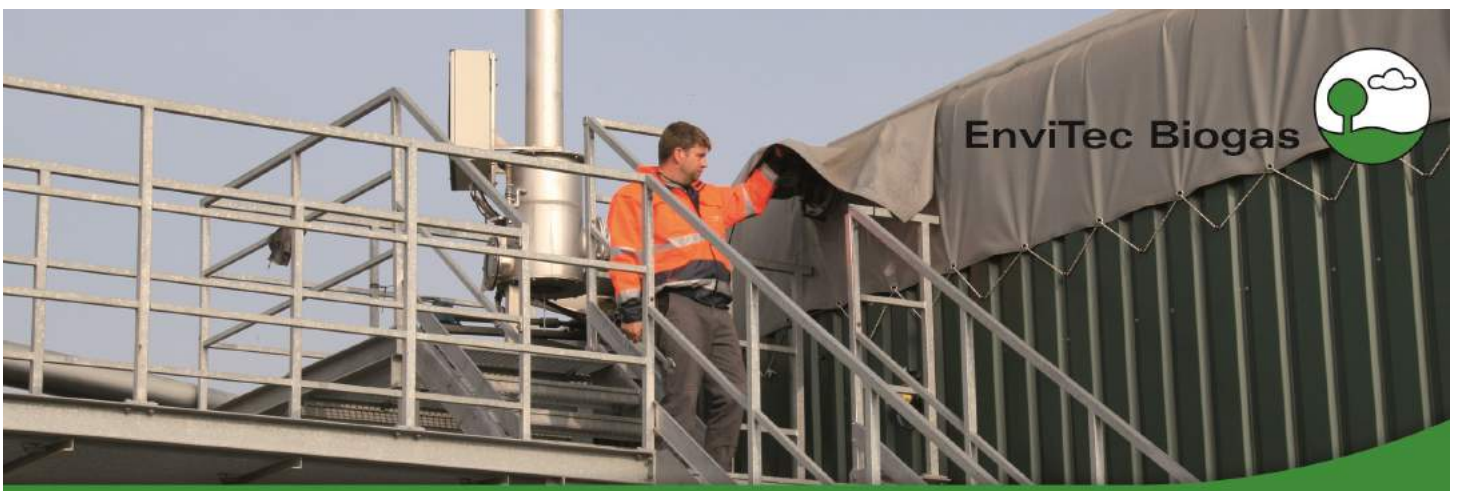



CONTACT US

ARM Buildings Limited
Rydal Estate, Colton Road
Rugeley, Staffordshire
WS15 3HF

For general enquiries and Equipment
Telephone: 01889 575055
E-mail: info@armbuildings.co.uk

For Building Design and Sale
Roger Smith
Sales & Contracts Director
Telephone: 01889 575055
E-mail: roger.smith@armbuildings.co.uk
Paul Marland
Sales Manager
Telephone: 01889 575055
E-mail: paul.marland@armbuildings.co.uk

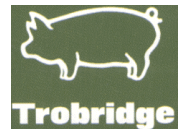

www.armbuildings.co.uk